

### DESCRIPTION

DZ 10 pressure snubber is designed to protect pressure transmitters from hydraulic shocks, such as water hammer. The liquid is being throttled on the way to the snubber output damping unwanted pressure spikes. DZ 10 can substantially increase the service life of the transmitter it protects.

### TECHNICAL SPECIFICATIONS

PARAMETER	VALUE
Housing material	stainless steel
Temperature range	up to +250 °C
Pressure range	up to 700 bar
Length	71 mm
Pressure port	G 1/2", G 1/4", 1/4" NPT, M20x1.5
Operation principle	throttling
Wetted materials	PTFE, brass

### DIMENSIONS (mm)

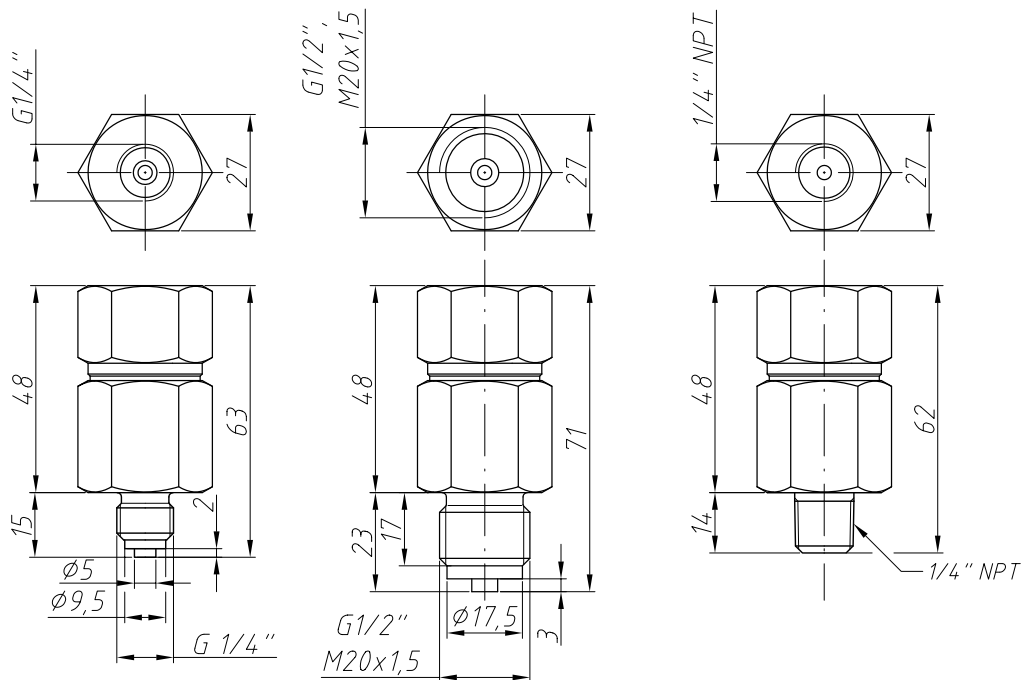

## ORDERING CODE

	DZ 10	-XXX	-XXX
<b>TRANSMITTER CONNECTION</b>			
	M20x1.5 int.	201	
	G1/2" int.	721	
	G1/4" int.	741	
	1/4" NPT int.	840	
	Other (specify when ordering)	XXX	
<b>PROCESS CONNECTION</b>			
		M20x1.5 EN 837	201
		G1/2" EN 837	721
		G1/4" int.	741
		1/4" NPT int.	840
		Other (specify when ordering)	XXX

Example: DZ 10-201-201